

# ON THE APPLICATION OF AUTONOMIC AND CONTEXT-AWARE COMPUTING TO SUPPORT HOME ENERGY MANAGEMENT

Boris Shishkov

*IICREST / TBM – Delft University of Technology, Jaffalaan 5, Delft, The Netherlands  
B.B.Shishkov@iicrest.eu, B.B.Shishkov@tudelft.nl*

Martijn Warnier

*TBM – Delft University of Technology, Jaffalaan 5, Delft, The Netherlands  
M.E.Warnier@tudelft.nl*

Marten van Sinderen

*IS – University of Twente, Drienerlolaan 5, Enschede, The Netherlands  
M.J.VanSinderen@ewi.utwente.nl*

**Keywords:** Green household; Home energy management; Autonomic computing; Context-aware computing.

**Abstract:** Conventional energy sources are becoming scarce and with no (eco-friendly) alternatives deployed at a large scale, it is currently important finding ways to better manage energy consumption. We propose in this paper ICT-related solution directions that concern the energy consumption management within a household. In particular, we consider two underlying objectives, namely: (i) to minimize the energy consumption in households; (ii) to avoid energy consumption peaks for larger residential areas. The proposed solution directions envision a service-oriented approach that is used to integrate ideas from Autonomic Computing and Context-aware Computing: the former influences our considering a selective on/off powering of thermostatically controlled appliances, which allows for energy redistribution over time; the latter influences our using context information to analyze the energy requirements of a household at a particular moment and based on this information, appliances can be powered down. Household-internally, this can help adjusting energy consumption as low as it can be with no violation of the preferences of residents. Area-wise, this can help avoiding energy consumption peaks. It is expected thus that such an approach can contribute to the reduction of home energy consumption in an effective and user-friendly way. Our proposed solution directions are not only introduced and motivated but also partially elaborated through a small illustrative example.

## 1 INTRODUCTION

Conventional energy sources are becoming scarce and with no (eco-friendly) alternatives deployed at a large scale, it is currently important finding ways to better manage energy consumption. This is a key challenge related to the societal goal of green household and sustainable living (Carvalho, 2009). Looking at this challenge from the perspective of a single household (as a unit) seems a logical starting point, before scaling up to collections of units, such as neighborhood, city, or region. Hence, we propose

in this paper ICT-related solution directions that concern the energy consumption management within a household. In particular, we consider two underlying objectives, namely: (i) to minimize the energy consumption in households; (ii) to avoid energy consumption peaks for larger residential areas.

The proposed solution directions envision a service-oriented approach that is used to integrate ideas from Autonomic Computing and Context-aware Computing.

Autonomic Computing (Kephart & Chess, 2003) has been proposed as a way to empower systems with self-management capabilities, in order to increase availability and reduce time-consuming and error-prone human management. Hence, Autonomic Computing can endow systems with properties, such as self-configuring, self-healing, and self-optimizing. This influences our considering a selective on/off powering of Thermostatically Controlled Appliances (TCAs), which allows for energy redistribution over time.

Context-aware Computing (Schilit et al., 1994) has been proposed as a way to allow systems to specialize their external behaviors depending on the perceived needs of their users. Perceived needs are deduced from context information which is captured in turn from context sources, such as sensors in the user environment. This influences our using context information to analyze the energy requirements of a household at a particular moment and based on this information, appliances can be powered down

As for TCAs (such as fridges, water heaters, air conditioners, and other energy-hungry appliances), they are in our focus mainly because of their great deal in the overall household energy consumption to date – taking for example USA, 25% of all household usage in the country points to TCAs. TCAs work in a periodic fashion by turning their thermostat ‘on’ and ‘off’. The thermostat keeps the temperature of the device within the target range of its operation, determined by a preference value pre-set by a human being. There is some freedom to time-shift the active/inactive state of these appliances without exceeding their target range of operation. Consequently, when considering a collection of TCAs, we may manage them in such a way that their active states have minimum overlap thus reducing peaks in electricity usage (load shifting). If we further could have real-time information available on the working environment of TCAs, such as the presence or activity mode of persons, it may be possible to decide whether the user set value for operation can be ignored. If such conditions exist, respective TCAs may be temporarily controlled on the basis of a lower set value, thus reducing average electricity usage. All those examples of intelligent management of TCAs, as mentioned in this paragraph, illustrate the potential for reducing home energy consumption, provided nevertheless we have means to capture, exchange and apply information on the status of home appliances and their environment. This not being the case with current energy management systems, inspires us for proposing a solution

influenced by Autonomic Computing and Context-aware Computing, as already mentioned.

Hence, household-internally, intelligently controlling TCAs’ performance can help adjusting energy consumption as low as it can be with no violation of the preferences of residents. Area-wise, this can help avoiding energy consumption peaks.

Finally, our envisioning a service-oriented approach (used to integrate ideas from Autonomic Computing and Context-aware Computing) is motivated by the ease and flexibility of composition and integration of application components, associated with the Service-Oriented Architecture (Erl, 2005; Leymann, 2005; Shishkov & Van Sinderen, 2009).

It is expected thus that such a service-oriented approach can contribute to the reduction of home energy consumption in an effective and user-friendly way. Our proposed solution directions are not only introduced and motivated but also partially elaborated through a small illustrative example.

The remaining of the paper is structured as follows: Section 2 elaborates the computing paradigms considered in this work, namely Autonomic Computing and Context-aware Computing. Section 3 introduces and motivates our proposed solution directions inspired by the mentioned computing paradigms. Section 4 partially elaborates the introduced solution directions through a small illustrative example. Section 5 discusses related work and Section 6 presents the conclusions.

## 2 BACKGROUND

This section provides relevant background information on Autonomic Computing and Context-aware Computing.

### 2.1 Autonomic Computing

Autonomic Computing (Kephart & Chess, 2003) has been proposed as a way to reduce the cost of maintaining complex systems, and to increase the human ability to manage these systems properly. Autonomic Computing introduces a number of autonomic properties, such as self-configuring, self-healing, self-optimizing and self-protecting. Extending and enhancing a system with these properties is an important step towards a self-management system.

In the context of knowledge based approaches IBM has introduced an abstract architecture for

Autonomic Computing (Ganek & Corbi, 2003) that identifies a number of fundamental concepts and architectural building blocks for constructing self-managed systems with autonomic properties. The two main building blocks of the Autonomic Computing architecture are autonomic managers and managed resources.

Managed resources are hardware or software components, for example a business application, a router or a database. A managed resource is managed by an autonomic manager. This autonomic manager forms the central part of the autonomic architecture. It collects data from managed resources, which is used for diagnosing failures and other unwanted behaviour. The autonomic manager formalizes and executes remedy plans for the managed resource which (should) correct the unwanted behaviour. Internally the autonomic manager implements a control loop that consist of four components, the so called MAPE (IBM Corporation 2005) functions: monitor, analyze, plan, and execute. The MAPE functions share a common knowledge base which is typically predefined and domain-specific, i.e. new knowledge is only added by system administrators and other users, the system itself does not learn.

## 2.2 Context-Aware Computing

Context-aware systems are primarily motivated by their potential to increase user-perceived effectiveness, i.e. to provide services that better suit the end-user's needs, by taking account of the user conditions. We refer to the collection of conditions which characterize an end-user or his/her immediate surroundings, and which are relevant for the system in pursuing user-perceived effectiveness, as end-user context, or **context** for short, in accordance to definitions found in literature (Dey et al., 2001).

Context-awareness implies that context information on the end-user must be captured, and preferably so without conscious or active involvement of the end-user. Context-aware systems can be particularly useful if the end-user is mobile and has a personal handheld device for the delivery of services. Mobility implies dynamic context. For example, different locations may have different social environments and different network access options, which offer opportunities for the provision of adaptive or value-added services based on context sensitivity. A context-aware system may provide near real-time context-based adaptation during a service delivery session with its mobile end-user.

Although context-aware systems have received much attention within the ICT research community, they have not been fully successful so far from a business point of view. This situation may change rapidly however, due to the increased capabilities and reduced prices of mobile devices, sensors, and wireless networks, and due to the introduction of new marketing strategies and service delivery models (De Reuver & Haaker, 2009).

## 3 BASIC ARCHITECTURE

As mentioned in Section 1, we are interested in pursuing two objectives with home energy management: reduction of average energy consumption and reduction of peak energy consumption. Our proposed approach is to apply results from Autonomic Computing and Context-aware Computing in order to contribute to the realization of these objectives. We introduce the following terms:

- *actual consumption*: this is the actual (measured) energy consumption of a collection of home appliances of interest;
- *consumption constraints*: these are the (maximum values) set for average and peak energy consumption;
- *perceived needs*: these are the perceived needs of the users regarding the operation of appliances (should they be on or off, or should their pre-set preference values be kept or lowered);
- *supported needs*: this is an indication of the needs that are supported by the current status (on/off) and setting (preference values) of appliances.

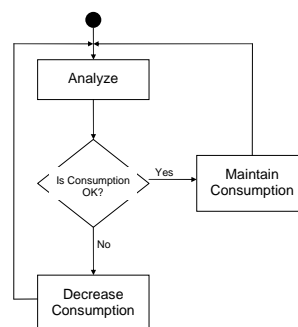

Figure 1: General plan for controlling home energy consumption.

The general idea is that we can analyze actual consumption with respect to consumption

constraints, and perceived needs with respect to supported needs. If either consumption constraints are (close to being) violated or supported needs are unnecessarily high, then energy consumption should be decreased and corresponding control actions need to be exercised on the appliances of interest. Figure 1 illustrates this general plan.

We will firstly address the problem of analyzing consumption and then consider the analysis of needs.

For analyzing consumption we adopt the MAPE control loop (see Section 2), considering a pool of appliances that are instrumented to allow monitoring and control. The monitoring consists of measuring the energy consumption of these appliances. The measurements are fed to a control process, which interprets these as the actual consumption, and compares the consumption with the consumption constraints. If, as a result of this analysis, it is decided that control actions are needed, an action plan is produced. The action plan is derived with an algorithm that considers time-shifting of the active state of appliances. Subsequently, the plan is executed by performing the indicated control actions on the selected appliances. Figure 2 illustrates the application of the MAPE control loop.

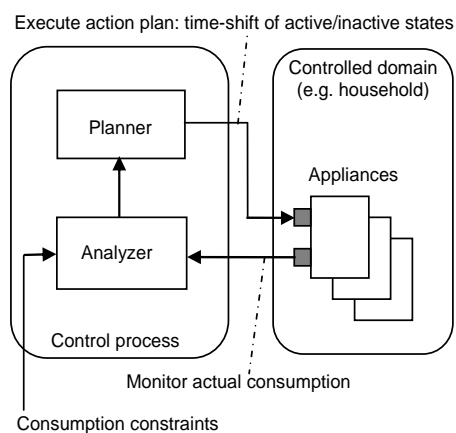

Figure 2: MAPE control loop applied to home energy management.

With regard to analyzing consumer needs, we adopt the *event-control-action* (ECA) pattern from context-aware computing (Dockhorn Costa et al., 2008). We consider the environment of the appliances, and assume that this environment is instrumented with sensors that are able to measure relevant conditions. For example, measurements may be used to determine context changes or situations, such as the presence of one or more persons in the house or in a particular room, the

activity mode (sitting, walking, sleeping) of a person, or a person entering or leaving the house. Context situations and changes can generally not be directly or reliably measured by a single sensor. A context management process is responsible for producing events that indicate the occurrence of a context situation or change, based on reasoning which potentially involves sensor data from several sources. Events are fed to a control process, which applies them in rules to determine actions related to perceived needs. For example, if nobody is in the house, a rule may establish the action to set the preferred value of the heating at 15 degrees Celsius. Whether the actions are really needed depends on the supported needs. For example, if the preferred value of the heating is already set to 15 degrees Celsius, no action is needed. The comparison of the perceived and supported needs leads to an action plan, which, if not empty, is subsequently executed by performing the indicated control actions on the selected appliances. Figure 3 illustrates the application of the ECA pattern.

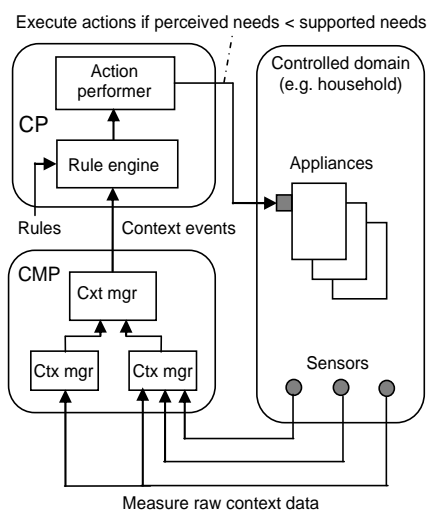

Figure 3: ECA pattern applied to home energy management (CP = Control Process, CMP = Context Management Process).

In order to combine the previously mentioned solution approaches, we need ease and flexibility in composing and integrating application components. We adopt a service-orientated architecture (SOA) because of its strengths in this direction (Leymann, 2005). In general, SOA brings flexibility to (re-)use applications and develop new applications and systems. Development may be fast and cost-effective with services of 3rd party applications. Maintenance is easy – implementations of services

can be replaced without affecting functionality and functionality might be changed or extended according to new requirements by changing or extending the composition of services. These strengths are relevant especially in our case of considering an ICT system for home energy management. For the sake of brevity, we will not elaborate further on SOA concepts and related standards, but instead refer interested readers to (Papazoglou, 2007). Services encapsulate ICT functionality and externalize their public functions through well-defined interfaces. By appropriately composing services, it is possible to support a desired business process. For achieving this, good coordination is required as well as proper information exchange.

We propose a service model that is driven by a coordination service and an information service. These services are essential since they support the deliveries of all other services. The coordination service orchestrates the overall work of the system, invoking other services at the right moment and offering them also the right input. This service is supported from the information service on most of the service invocations because in invoking a service, specific and actual information inputs would be needed. This vision is reflected in Figure 4.

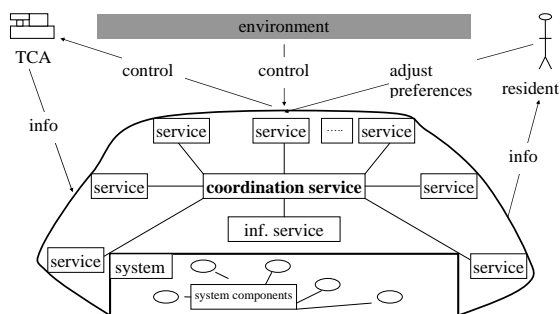

Figure 4: Facilitating residents, appliances and their environment in a service-oriented way.

As shown in Figure 4, all services, including the coordination service and information service, have their underlying software/hardware components which implement required ICT functionality.

Our service model helps to bridge between user needs and system capabilities, by considering the entities involved: (i) residents who have their own preferences; (ii) Home appliances which have their own capabilities; (iii) the living environment having its own characteristics. What the system would typically do is.

- Let a resident adjust personal preferences and if possible adjust appliances in such a way that those are met;
- Inform a resident about the household energy consumption;
- Monitor appliances, by properly capturing information that reflects their energy consumption;
- Exercise control over appliances driven by external request(s) and/or residents' preferences;
- Allow external control that is in line with relevant public regulations

## 4 EXAMPLE

To illustrate our basic architecture we return to the TCA example mentioned in Section 1. Specifically, we consider a 2-person household with a fridge, a freezer and a central heating system. All TCAs are equipped with sensors to measure performance of the appliances. Additional sensors are present throughout the house. These sensors are used to collect relevant context information, e.g. to determine if a person is in the house, in which room (s)he is, and what (s)he is doing (active, sitting, sleeping). Both context information and TCA-specific information is sent to an analysis service.

This analysis service keeps track of the current state of energy consumption and predicts what energy usage is required in the (near) future. For example, if a resident enters his/her empty house it can be expected that energy usage as a whole will rise. Behavioral patterns of the residents of a house can be learned: does a person usually start with preparing a meal within 30 minutes after arriving in the evening? This information can gradually be acquired by analyzing the energy usage of the residents over a longer period of time. The analysis service should learn from the residents and be adaptive to their behavior. It should also take factors into account that are external to the household. If peak usage in a neighborhood should be avoided, control systems of different households should coordinate their behavior to jointly prevent this.

The information that the analysis service acquires is necessary for the planning service. This service needs to carefully plan how the TCAs in the household should function for a given time period. It is essential that this service can coordinate the energy usage of the different appliances. TCAs can all be put on and off in sync or, in contrast, be put on and off alternating over different time periods. The

planning service will select the appropriate energy consumption plan for each appliance, based on the requirements of the analysis service.

The execution plans for the individual devices are then forwarded by a **control service** to the fridge, the freezer and the central heating system, where they are executed.

The residents can give their own requirements to the system. For example, if the house is empty or the residents are sleeping, the preferred room temperature can be decreased to 15 °C.

A **coordination service** is needed to orchestrate the overall work of the system, invoking other services at the right moment and offering them also the right input, which service. This service in turn is supported by an **information service**.

Based on this example, we can thus identify 5 services. These services can be included as building blocks in a SOA-based platform in the area of home energy management, in addition to middleware functions that support the realization on particular platforms and technologies.

## 5 RELATED WORK

In the domain of energy management, research mainly focuses on either energy management on the provider side or on management at the consumer side. The latter is often referred to as 'demand side management' and forms the main focus of this paper.

To the best of our knowledge, little work has been done on demand side energy management systems that consider context information, such as if a person is present in a house or not. As mentioned in Section 5, an important challenge is the development of reasoning algorithms that can defer relevant and reliable context information from raw context data produced by low cost sensors. Roy et al. (2006) propose an algorithm that makes location and activity tracking in multi-inhabitant homes possible, enabling an adaptive energy management scheme. Our approach is more general, targeted to architectural solutions, and could benefit from the incorporation of such algorithms.

Most related approaches on demand side management however do not consider context, but monitor actual consumption and apply some form of load-shifting.

Dynamic energy markets have been used to stimulate the energy usage of users. These markets allow users to actively buy energy for a certain time slot, usually a couple of hours, while the price changes dynamically with demand. This can be

exploited for load shifting, as has been shown by the work of Faruqui and George (2005), McDonough and Kraus (2007) and Hopper et al. (2006). In contrast to our work, an open energy market that allows energy contracts for short periods of time is required for these approaches.

Stadler et al. (2009) consider cooling devices which are switched off during peak usage and switched back on when energy consumption usage of the grid is low. The grid itself signals the devices when either condition is met. In contrast to our work, here all devices are either on or off, no mixing of on and off devices is allowed.

Pournaras, Warnier and Brazier (2009) propose EPOS, the Energy Plan Overlay Self-stabilisation system. In this work TCAs are controlled by software agent and organized in a tree overlay. The global goal of stabilization emerges through local knowledge, local decisions and local interactions among the software agents. EPOS mainly deals with the scalability issues that arise when thousands of TCAs have to communicate with each other. Our approach starts with energy management in individual households, and scalability over more devices should be more clustered, going from households, to city blocks, to neighborhoods to towns and regions.

Energy management has further mainly been deployed in industrial settings. Middelberg, Zhang and Xia (2009) propose an approach based on a binary integer programming problem that addresses the energy management of a colliery. A similar integer programming model is proposed by Asok (2006) for the energy management of steel plants. In both cases the environment is relatively static and no context information is required. Both approaches lack adaptive behaviour and seem to be less applicable to demand side energy management in households.

## 6 CONCLUSIONS

In this paper, we have presented solution directions that concern the application of two computing paradigms to support home energy management, namely Autonomic Computing and Context-aware Computing. In particular, we have proposed an energy management approach, based on ideas from the mentioned paradigms, and using a service-oriented architecture. We believe that this represents a modest but useful contribution to finding technical solutions for more advanced home energy management visions, taking the following into

account as distinctive features of our solution directions:

- well-established monitoring and control mechanisms concerning energy-consuming appliances;

- near real-time context-based adaptation during a service delivery that allows for adjusting energy-consuming appliances in such a way that adequately suits the residents' needs, by taking account of their conditions;

- ease and flexibility in composing and integrating application components.

Inspired by this work, we envision furthering our research in the following directions: (i) continuing with the development of the proposed approach at a lower level, considering particular platforms and technologies through which the approach could be realized; (ii) exploratory case-study research that would help considering our approach in real-life context, which would be of great importance for adding more practical insight as enrichment to our ideas; (iii) re-visiting our peak-prediction vision, by considering probabilities and statistics, for supporting our system in a sound and reliable way; (iv) acquiring more specific domain knowledge from environmental organizations and energy companies with the purpose of tuning our approach in such a way that it is maximum useful in supporting real-life problems; (v) analyzing this usefulness in different ways, including through simulation, that would provide valuable feedback for us as architects but would also facilitate our discussions with domain experts who would better understand our nicely visualized ideas.

As for the realization of the proposed solution directions, we envision several main challenges: (i) scaling up to collections of households, taking into account that our solutions would have to be repeated at different granularity levels (e.g. household, residential area, city); (ii) peak prediction indicators should be identified, for reliably predicting consumption peaks; (iii) algorithms are needed to support the schemas for consumption decrease that may be enforced; (iv) needs of the residents should be considered carefully, in order to avoid irritations that result from enforced consumption decreases; (v) intelligent consumption scheduling and/or other alternatives to consumption decrease should be considered in this is better for the comfort of residents.

## REFERENCES

- Ashok, S., 2006. Peak-load management in steel plants, In: *Applied Energy* 83(5), 413 – 424.
- Carvalho, Maria da Graca, 2009. Building a low carbon society. In: 5th Dubrovnik Conf. on Sustainable Dev. of Energy Water and Environm. Systems.
- De Reuver, M., Haaker, T., 2009. Designing viable business models for context-aware services, *Telematics and Informatics* 26(3), 240-248.
- Dey, A., Abowd, G.D., Salber, D., 2001. A conceptual framework and toolkit for supporting rapid prototyping of context-aware applications, *HCI* 16(2), 97-166.
- Dockhorn Costa, P. and Ferreira Pires, L. and van Sinderen, M.J., 2008. Concepts and architectures for mobile context-aware applications. In: *Research on mobile multimedia*. Inf. Science Ref., Hershey, NY.
- Erl, T., 2005. *Service-oriented architecture: concepts, technology, and design*, Prentice Hall PTR, NJ.
- Faruqui, A. & George, S., 2005. Quantifying customer response to dynamic pricing. In: *The Electricity Journal* 18(4), 53–63.
- Ganek, A.G. and Corbi, T.A., 2003. The dawning of the Autonomic Computing era. *IBM Systems Journal* 42-1.
- Hopper, N., Goldman, C., Bharvirkar, R., Neenan, B., 2006. Customer response to day-ahead market hourly pricing: Choices and performance, *Util. Policy* 14(2), 126–134.
- IBM Corporation, 2005. *An architectural blueprint for Autonomic Computing*. White Paper.
- Kephart, J.O. and Chess, D.M., 2003. *The vision of Autonomic Computing*. IEEE Computer Society.
- Leymann, L., 2005. Combining web services and the grid: Towards adaptive enterprise applications. *CAiSE Workshops* (2), 9-21
- Mazza, P., 2002. The smart energy network: Electrical power for the 21st century. *Climate Solutions*.
- McDonough, C. & Kraus, R., 2007. Does dynamic pricing make sense for mass market customers? In: *The Electricity Journal* 20(7), 26–37.
- Middelberg, A., Zhang, J. & Xia, X., 2009. An optimal control model for load shifting - With application in the energy management of a colliery. In: *Applied Energy* 86(7-8), 1266 – 1273.
- Papazoglou, M., 2007. *Web services: principles and technology*. Boston: Pearson Prentice Hall.
- Pournaras, E., Warnier, M. and Brazier, F. M. T., 2009. A Distributed Agent-based Approach to Stabilization of Global Resource Utilization. In: *Int. Conf. on Complex, Intelligent and Software Intensive Systems (CISIS'09)*.
- Roy, N., Roy, A., Das, S.K., 2006. Context-aware resource management in multi-inhabitant smart homes: a Nash H-learning based approach, In: *PERCOM 2006*, IEEE.
- Schilit, B., Adams, N., Want, R., 1994. Context-aware computing applications, In: *WMCSA 1994*, IEEE Computer Society, 85-90.
- Shishkov, B. and Van Sinderen, M.J., 2009. Service-oriented coordination platform for technology-enhanced learning. In *I-WEST'09, 3rd Int. Workshop on Enterprise Systems and Technology*. INSTICC Press.
- Stadler, M., Krause, W., Sonnenschein, M. & Vogel, U., 2009. Modelling and evaluation of control schemes for enhancing load shift of electricity demand for cooling devices. In: *Env. Modelling & Software* 24(2), 285 – 295.